

DIGIFLO

ELECTRONIC FLOWMETER

PIPE FITTING INSTALLATION

MANUAL

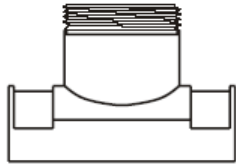

SADDLE

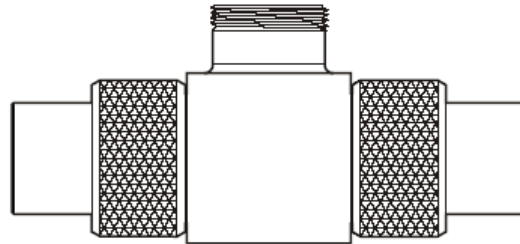

MACHINED IN-LINE BODY

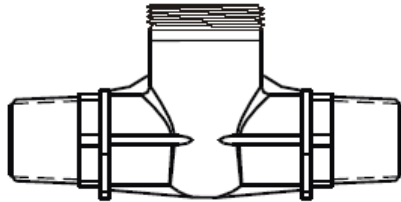

MOLDED IN-LINE BODY

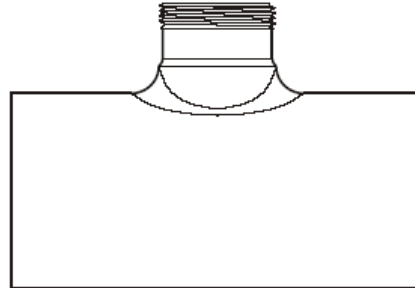

MOLDED TEE

FLOMETERS A division of Pathfinder Instruments, LLC

800-284-9698 / 760-438-0890 Fax: 760-4383953

Email: info@flometers.com

1.0 Temperature vs. Pressure

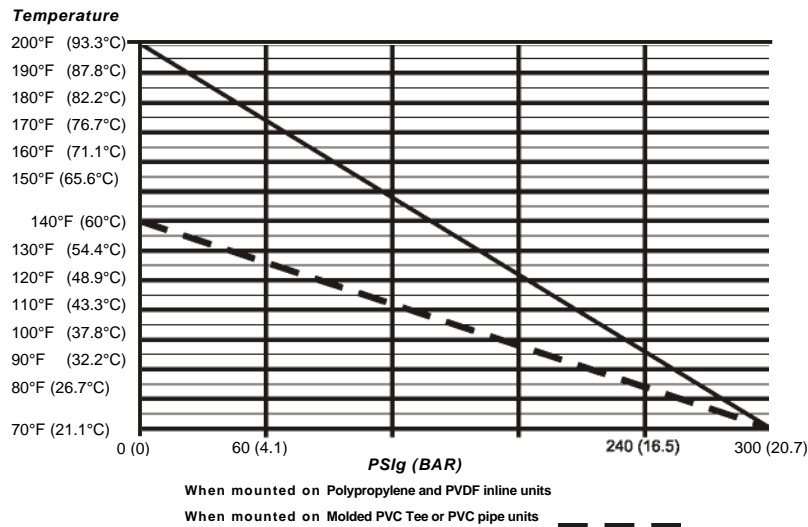

Note: Pressure and temperature limits are inversely proportional.

Fig. 1

2.0 Calibration Constants

Note: The values in the following tables are based on laboratory testing of nominal pipe dimensions. The F-2000 sensor is factory calibrated to ±1 % of full scale linearity. Your actual accuracy will vary based on your pipe I.D. And other installation factors.

METRIC PIPE PN10 & PN16 (Meets DIN 8062)

Saddle Mount Models (Pipe Insertion connection)

Standard Flow Range - LPM (liters per minute)

Pipe Size (MM)	PN Rating	Pipe I.D. (MM)	Flow Range (LPM)	K-Factor (Pulse/L)	Rate Scale Factor (Sr)	Rate Display Decimal Point	Total Scale Factor (St)	Total Display
50	10	45.2	70.0 - 700.0	16.561	36.2297	0000.0	00.0604	00000
50	16	42.6	70.0 - 700.0	20.719	28.9588	0000.0	00.0483	00000
63	10	57.0	110 - 1100	10.522	05.7023	00000	00.0950	00000
63	16	53.6	110 - 1100	11.830	05.0720	00000	00.0845	00000
90	10	81.4	230 - 2300	5.294	11.3335	00000	00.1889	00000
90	16	76.6	230 - 2300	5.944	10.0944	00000	00.1682	00000
110	10	99.4	350 - 3500	2.942	20.3969	00000	00.3399	00000
110	16	93.6	350 - 3500	3.107	19.3133	00000	00.3219	00000
160	10	144.6	720 - 7200	1.386	43.2782	00000	00.7213	00000
160	16	136.2	720 - 7200	1.574	38.1081	00000	00.6351	00000
200	10	180.8	1150 - 11500	0.927	64.7077	00000	01.0785	00000
200	16	170.2	1150 - 11500	1.008	59.5501	00000	00.9925	00000
250	10	226.2	1700 - 17000	0.565	106.232	00000	01.7705	00000
315	10	285.0	2700 - 27000	0.353	170.003	00000	02.8334	00000

I.P.S. PIPE (Meets ASTM-D-1785)

Molded Inline Bodies (Male NPT connection)

3/8" - 1" pipe sizes - Standard Range #1 - GPM (gallons per minute)

Pipe Size (in.)	Pipe Sch.	Body I.D. (In.)	Flow Range (GAL/Min)	K-Factor (Pulse/GAL)	Rate Scale Factor (Sr)	Rate Display Decimal Point	Total Scale Factor (St)	Total Display Decimal Point
3/8	Inline	0.375	.800 - 8.000	1456.31	41.2000	00.000	00.0069	0000.0
1/2	Inline	0.500	2.00 - 20.00	1034.48	05.8000	000.00	00.0097	0000.0
3/4	Inline	0.660	3.00 - 30.00	612.25	09.8000	000.00	00.0163	0000.0
1.0	Inline	0.840	5.00 - 50.00	338.60	17.7200	000.00	00.0295	0000.0

3/8" - 1" pipe sizes - Low Range #2 - GPM (gallons per minute)

Pipe Size (in.)	Pipe Sch.	Body I.D. (In.)	Flow Range (GAL/Min)	K-Factor (Pulse/GAL)	Rate Scale Factor (Sr)	Rate Display Decimal Point	Total Scale Factor (St)	Total Display Decimal Point
3/8	Inline	0.218	.400 - 4.000	2926.83	20.5000	00.000	00.0034	0000.0
1/2	Inline	0.250	.500 - 5.000	2419.35	24.8000	00.000	00.0041	0000.0
3/4	Inline	0.375	.800 - 8.000	1518.99	39.5000	00.000	00.0066	0000.0
1.0	Inline	0.500	2.00 - 20.00	1034.48	05.8000	000.00	00.0097	0000.0

Molded Inline Bodies (Male NPT connection) - continued

1-1/2" - 2" pipe sizes - GPM (gallons per minute)

					RATE 1	RATE 2	TOTAL 1	TOTAL 2
Pipe Size (in.)	Pipe Sch.	Flow Range #	Flow Range (GAL/Min)	K-Factor (Pulse/GAL)	Rate Scale Factor (Sr)	Rate Display Decimal Point	Total Scale Factor (St)	Total Display Decimal Point
1-1/2	Inline	1	4.00 - 40.00	466.20	12.8700	000.00	00.0215	0000.0
1-1/2	Inline	2	6.00 - 60.00	192.93	31.0994	000.00	00.0518	0000.0
1-1/2	Inline	3	10.0 - 100.0	156.94	3.8231	0000.0	00.0637	0000.0
2	Inline	1	4.00 - 40.00	468.75	12.8000	000.00	00.0213	0000.0
2	Inline	2	6.00 - 60.00	196.40	30.5499	000.00	00.0509	0000.0
2	Inline	3	10.0 - 100.0	162.16	3.7000	0000.0	00.0617	0000.0
2	Inline	4	20.0 - 200.0	67.416	8.9000	0000.0	00.1483	0000.0

Machined Inline Bodies (Female NPT connection)

Standard Flow Range #1 - GPM (gallons per minute)

					RATE 1	RATE 2	TOTAL 1	TOTAL 2
Pipe Size (in.)	Pipe Sch.	Body I.D. (In.)	Flow Range (GAL/Min)	K-Factor (Pulse/GAL)	Rate Scale Factor (Sr)	Rate Display Decimal Point	Total Scale Factor (St)	Total Display Decimal Point
3/8	Inline	0.375	.800 - 8.000	1469.87	40.8200	00.000	00.0068	0000.0
1/2	Inline	0.500	2.00 - 20.00	985.22	06.0900	000.00	00.0102	0000.0
3/4	Inline	0.750	4.00 - 40.00	471.70	12.7200	000.00	00.0212	0000.0
1.0	Inline	1.000	6.00 - 60.00	204.08	29.4000	000.00	00.0490	0000.0
1-1/2	Inline	1.500	15.0 - 150.0	93.095	6.4451	0000.0	00.0107	00000
2.0	Inline	1.900	30.0 - 300.0	50.439	11.8956	0000.0	00.0198	00000

					RATE 1	RATE 2	TOTAL 1	TOTAL 2
				K-Factor (Pulse/GAL)	Rate Scale Factor (Sr)	Rate Display Decimal Point	Total Scale Factor (St)	Total Display Decimal Point
				3468.21	17.3000	00.000	00.0029	0000.0
				2631.58	22.8000	00.000	00.0038	0000.0
				1469.87	40.8200	00.000	00.0068	0000.0
				985.22	06.0900	000.00	00.0102	0000.0
				134.06	4.4757	0000.0	00.0075	00000
Pipe Size (in.)				93.095	6.4451	0000.0	00.0107	00000

					RATE 1	RATE 2	TOTAL 1	TOTAL 2
				K-Factor (Pulse/GAL)	Rate Scale Factor (Sr)	Rate Display Decimal Point	Total Scale Factor (St)	Total Display Decimal Point
		(GAL/Min) 1-1/2		204.08	29.4000	000.00	00.0490	0000.0
	Inline			985.22	6.0900	000.00	00.0102	0000.0
		3		1283.88	4.6733	000.00	00.0078	0000.0
1-1/2			6.00 - 60.00	134.06	4.4757	0000.0	00.0075	00000
	Inline			204.08	29.4000	000.00	00.0490	0000.0
		4		471.70	12.7200	000.00	00.0212	0000.0
1-1/2			2.00 - 20.00	985.22	6.0900	000.00	00.0102	0000.0
	Inline							
		5						
			1.00 - 20.00					

					RATE 1	RATE 2	TOTAL 1	TOTAL 2
Pipe Size (in.)	Pipe Sch.	Pipe I.D. (In.)	Flow Range (GAL/Min)	K-Factor (Pulse/GAL)	Rate Scale Factor (Sr)	Rate Display Decimal Point	Total Scale Factor (St)	Total Display Decimal Point
1.5	40	1.610	15.0 - 150.0	86.580	06.9300	0000.0	00.0116	00000
1.5	80	1.500	15.0 - 150.0	102.04	05.8800	0000.0	00.0098	00000
2.0	40	2.067	30.0 - 300.0	50.850	11.7994	0000.0	00.0197	00000
2.0	80	1.939	30.0 - 300.0	58.820	10.2006	0000.0	00.0170	00000
3.0	40	3.068	60.0 - 600.0	21.820	27.4977	0000.0	00.0458	00000
3.0	80	2.900	60.0 - 600.0	24.000	25.0000	0000.0	00.0417	00000
4.0	40	4.026	100 - 1000	11.8577	05.0600	00000	00.0843	00000
4.0	80	3.826	100 - 1000	12.7659	04.7000	00000	00.0783	00000
6.0	40	6.065	250 - 2500	5.3507	11.2135	00000	00.1869	00000
6.0	80	5.761	250 - 2500	5.5738	10.7647	00000	00.1794	00000
8.0	40	7.981	400 - 4000	2.985	20.1000	00000	00.3350	00000
8.0	80	7.625	400 - 4000	2.940	20.4082	00000	00.3401	00000
10.0	40	10.020	600 - 6000	1.594	37.6412	00000	00.6274	00000
10.0	80	9.564	600 - 6000	1.845	32.5203	00000	00.5420	00000
12.0	40	11.938	800 - 8000	1.116	53.7634	00000	00.8961	00000
12.0	80	11.376	800 - 8000	1.296	46.2963	00000	00.7716	00000

3.0 PIPE INSTALLATION REQUIREMENTS

3.1 Flow Stream Requirements

- The F-2000 accuracy is based on steady, undisturbed flow with a fully developed **turbulent** flow profile. Pulsating, swirling and other disruptions in the flow stream will effect the meters accuracy.
- There are two basic types of flow profiles; **turbulent** and **laminar** (see figure 2).

Turbulent flow exists when the speed of the fluid flowing in the pipe is nearly constant across the entire width of the pipe. This is typical of low viscosity fluids like water, flowing at high velocity.

Laminar flow exists when the speed of the fluid flowing in the center of the pipe is greater than the speed of the fluid at the outer edge near the pipe wall. This is typical of high viscosity fluids flowing at low velocity. Because the F-2000 is measuring the fluid near the pipe wall only (especially in larger pipe sizes), a constant flow velocity across the flow stream is required.

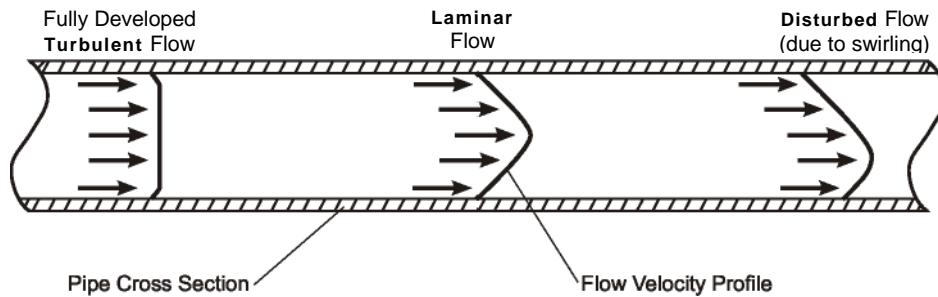

Fig. 2

To determine which type of flow exists in your installation, the following is required:

- Flow rate of the fluid in GPM = Q
- Specific gravity of the fluid = G
- Pipe inside diameter in inches = D
- Fluid viscosity in centipoise = V

Use the following equation to determine the REYNOLDS NUMBER:

$$\text{REYNOLDS NUMBER} = \frac{3160 \times Q \times G \times D}{V}$$

Flow conditions with a Reynolds Number greater than 4000 is fully developed **turbulent** flow.

A Reynolds Number less than 2000 is laminar flow. The F-2000 requires a Reynolds number greater than 4000 to maintain accuracy.

3.1 Minimum Pipe Length Requirements

The F-2000 accuracy is affected by disturbances such as pumps, elbows, tees, valves in the flow stream. Install the meter in a straight run of pipe **as far as possible** from any disturbances. The distance required for accuracy will depend on the type of disturbance. (see figure 3 and 4).

Type Of Disturbance	Minimum Inlet Pipe Length	Minimum Outlet Pipe Length
Flange	10 X Pipe Inside Diameter	5 X Pipe Inside Diameter
Reducer	15 X Pipe Inside Diameter	5 X Pipe Inside Diameter
90 ° Elbow	20 X Pipe Inside Diameter	5 X Pipe Inside Diameter
Two 90 ° Elbows -1 Direction	25 X Pipe Inside Diameter	5 X Pipe Inside Diameter
Two 90 ° Elbows -2 Directions	40 X Pipe Inside Diameter	5 X Pipe Inside Diameter
Pump Or Gate Valves	50 X Pipe Inside Diameter	5 X Pipe Inside Diameter

4.0 HOW TO INSTALL THE F-2000

The F-2000 was designed to be installed and operated by qualified personnel only. Do not attempt to install or operate the F-2000 if you are unsure. Seek qualified assistance. Please note that warranty coverage does not include damage due to misuse or improper installation.

4.1 Mounting Location

- The F-2000 is designed to withstand outdoor conditions. A cool, dry location, where the unit can be easily serviced is recommended.
- The F-2000 can be mounted on horizontal or vertical runs of pipe (see figure 3 and 4). Mounting at the vertical (twelve o'clock) position on horizontal pipe is recommended (see figure 7). Mounting anywhere around the diameter of vertical pipe is acceptable, however, the pipe must be completely full of water at all times. Back pressure is essential on downward flows.
- The F-2000 can accurately measure flow from either direction provided the minimum inlet and outlet conditions are met.

Horizontal Mount
Fig. 3

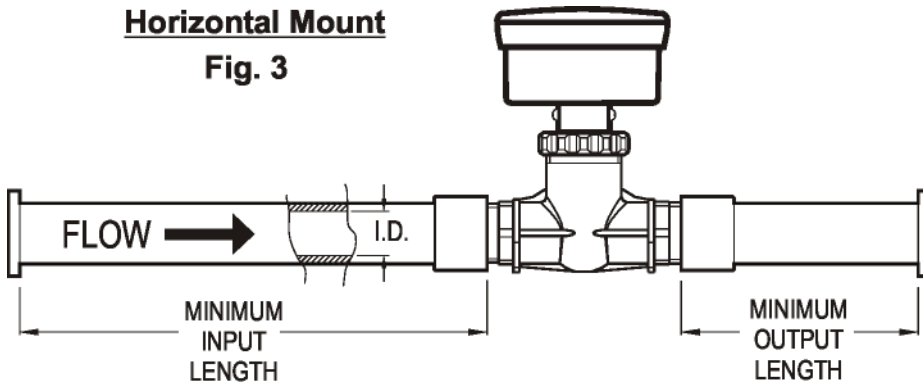

*See Minimum Pipe Lengths table on previous page.

Angle Mount on Horizontal Pipe

Fig. 5

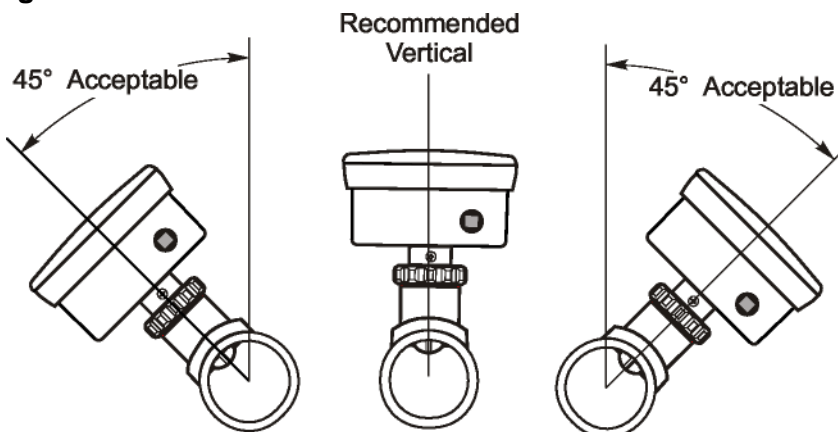

Vertical Mount

Fig. 4

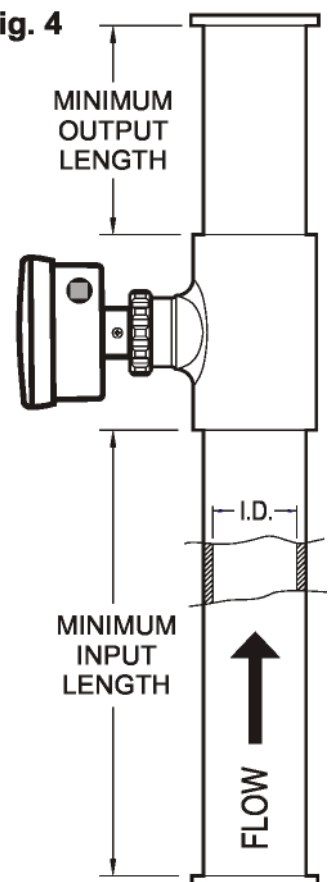

5.0 How To Install Your F-2000 Saddle Fitting

The F-2000 saddle is designed to mount on smooth schedule 40 IPS pipe, schedule 80 IPS pipe (ASTM-D-1785), PN10 metric pipe or PN16 metric pipe (DIN 8062). The outside of the pipe must be clean, smooth and free of surface imperfections. The outside diameter must be as specified to ensure a leak free installation. The inside diameter must be as specified to ensure meter accuracy.

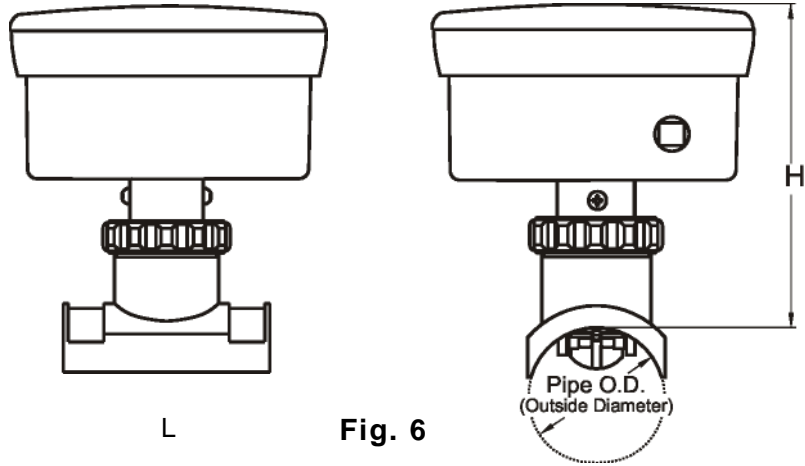

Fig. 6

I.P.S. Pipe Sizes (in inches) (ASTM-D-1785)

Nominal Pipe Size	Length (L)	Height (H)	Schedule 40		Schedule 80	
			Outside Diameter	Inside Diameter	Outside Diameter	Inside Diameter
1-1/2"	3-3/16"	4-1/2"	1.900	1.610	1.900	1.500
2"	3-3/16"	4-1/2"	2.375	2.067	2.375	1.939
3"	3-3/16"	4-1/2"	3.500	3.068	3.500	2.900
4"	3-3/16"	4-1/2"	4.500	4.026	4.500	3.826
6"	3-3/16"	4-3/8"	6.625	6.065	6.625	5.761
8"	3-3/16"	4-3/8"	8.625	7.981	8.625	7.625
10"	4-1/2"	4-1/2"	10.750	10.020	10.750	9.564
12"	4-1/2"	4-1/2"	12.750	11.938	12.750	11.376

Metric Pipe Sizes (in millimeters) (DIN 8062)

Nominal Pipe Size	Length (L)	Height (H)	Pn10		Pn16	
			Outside Diameter	Inside Diameter	Outside Diameter	Inside Diameter
50mm	81	114	50.0	45.2	50.0	42.6
63mm	81	114	63.0	57.0	63.0	53.6
90mm	81	114	90.0	81.4	90.0	76.6
110mm	81	114	110.0	99.4	110.0	93.6
160mm	81	110	160.0	144.6	160.0	136.2
200mm	81	110	200.0	180.8	200.0	170.2
250mm	114	114	250.0	226.2	N/A	N/A
315mm	114	114	315.0	285.0	N/A	N/A

Step 1 **Drill The Mounting Hole**

- Select an area on the pipe. Be sure the surface area of the pipe is clean and smooth.
- F-2000 can accurately measure flow either direction provided the minimum inlet and outlet conditions are met.
- Drill a 1-1/8" diameter hole through the center of the pipe wall. On horizontal installations, drill the hole as close to the vertical (12 O'clock) position as possible. Do not exceed 45° from vertical. See figure 5. A hole saw kit is available from the factory, order **part number 20000-062**.
- Clean all burrs from inside and outside the hole. Use fine sandpaper (440 grit) if necessary.

Step 2 **Install The Saddle**

- Insert the alignment tool through the top of the saddle. Slide the large O-ring over the bottom of the alignment tool and into the groove on the underside of the saddle.
- With the alignment tool and O-ring in place, position the saddle over the drilled hole. Insert the alignment tool into the hole seating the saddle. Be sure the O-ring is properly seated in the O-ring groove.
- Place the pipe clamps around the pipe and into the slots on the saddle. Tighten the clamps in an alternating method.

Step 3 **Check The Saddle Alignment**

- Pull the alignment tool out of the saddle. If the tool is not easily removed, the alignment is not correct. Slightly loosen the clamps and insert the tool. The saddle must be mounted directly over the hole. Adjust the saddle alignment until the alignment tool slides freely in and out of the saddle.
- Be certain the O-ring is properly seated and visible in the groove around the hole.
- Tighten the clamps.

Step 4 **Install The F-2000 Sensor**

- Be sure two O-rings are located on the sensor body (see figure 7). The O-rings have been lubricated at the factory with silicone oil.
- Push the sensor assembly into the saddle with a twisting motion. The notch on the sensor body must fit into the slot on the saddle. Be sure the sensor is fully inserted into the saddle.
- HAND TIGHTEN the black union nut. Do not tighten the nut with a tool.

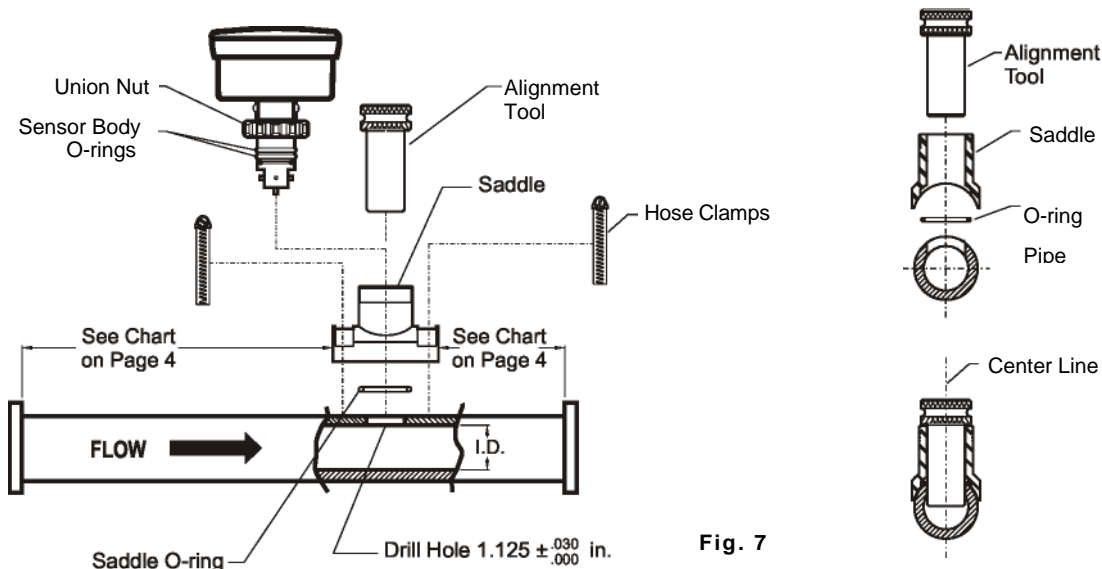
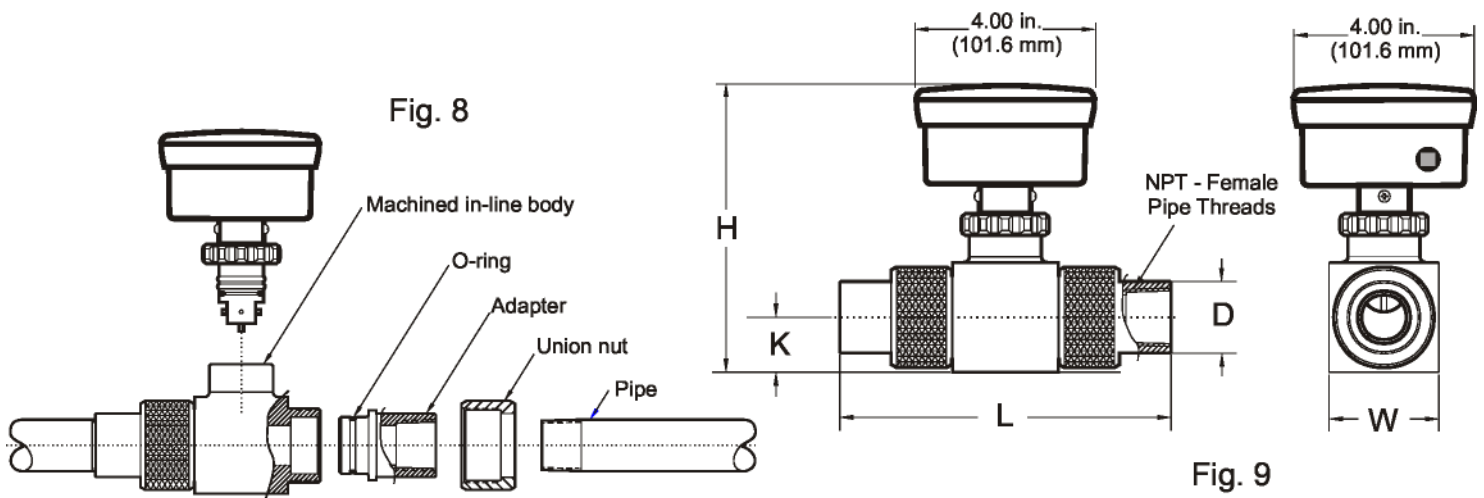

Fig. 7

9.0 Installing The Machined In-line Fitting (PI)

The machined in-line fittings consist of a meter body, two pipe adapter fittings (inlet and outlet), and two half union nuts. Pipe adapters are supplied with female American National Standard Taper Pipe Threads (NPT). The adapters are secured to the meter body with half union nuts and sealed with Viton O-rings.

- Select an area on the pipe as outlined in section 4.1.
- The F-2000 can accurately measure flow from either direction provided the minimum inlet and outlet conditions are met. Section 3.1
- Install the F-2000 as you would any other plastic pipe fitting. Because the F-2000 uses half union nut style connections, the adapters can be installed on the piping system first and then secured to the meter body with the unions.
- The F-2000 can be mounted on horizontal or vertical runs of pipe. Mounting at the vertical (twelve o'clock) position on horizontal pipe is recommended (see figure 5). Mounting anywhere around the diameter of vertical pipe is acceptable, however, the pipe must be completely full of water at all times.
- Be sure the inlet and outlet fittings are aligned properly. Improper alignment the fittings will put stress on the adapter connections and may cause leaking or fitting damage.
- Do not over tighten the fittings. Hand tighten only.
- Use Teflon [®] tape sealant only on the adapter threads. Do not use pipe dope or glue.
- Be sure the inlet and outlet plumbing is properly secured. The F-2000 is not designed to support the weight of related piping. Improperly supported pipes will put stress on the adapter connections and may cause leaking or



Nominal Pipe Size	Pipe Threads Size	Overall Length L	Overall Height H	Center Height K	Adapter O.D. D	Body Width W
3/8"	3/8" - FNPT	7.4" (188 mm)	6.3" (159 mm)	1.22" (31 mm)	1.60" (40.6 mm)	2.45" (62 mm)
1/2"	1/2" - FNPT	7.4" (188 mm)	6.3" (159 mm)	1.22" (31 mm)	1.60" (40.6 mm)	2.45" (62 mm)
3/4"	3/4" - FNPT	7.4" (188 mm)	6.3" (159 mm)	1.22" (31 mm)	1.60" (40.6 mm)	2.45" (62 mm)
1.0"	1.0" - FNPT	7.4" (188 mm)	6.3" (159 mm)	1.22" (31 mm)	1.60" (40.6 mm)	2.45" (62 mm)
1-1/2"	1-1/2" - FNPT	9.4" (239 mm)	6.6" (167 mm)	1.70" (43 mm)	2.50" (63.5 mm)	2.5" (63 mm)
2.0"	2.0" - FNPT	11.4" (290 mm)	7.1" (180 mm)	2.00" (51 mm)	3.08" (78.2 mm)	3.0" (76 mm)

7.0 Installing The Molded In-Line Fitting (MI)

All molded in-line (MI) fittings have male American National Standard Taper Pipe Threads (MPT).

- Select an area on the pipe as outlined in section 4.1.
- The F-2000 can accurately measure flow from either direction provided the minimum inlet and outlet conditions are met. Section 3.1
- Install the F-2000 as you would any other plastic pipe fitting. Be sure the inlet and outlet fittings are aligned properly. Improper alignment of the fittings will put stress on the adapter connections and may cause leaking or fitting damage. Do not over tighten the fittings. Use Teflon® tape sealant only on the adapter threads.
- The F-2000 can be mounted on horizontal or vertical runs of pipe. Mounting at the twelve o'clock position on horizontal pipe is recommended. Mounting anywhere around the diameter of vertical pipe is acceptable, however, the pipe must be completely full of water at all times. See figure 3, 4 and 5.
- Be sure the inlet and outlet plumbing is properly secured. The F-1000 is not designed to support the weight of related piping. Improperly supported pipes will put stress on the adapter connections and may cause leaking or fitting damage.

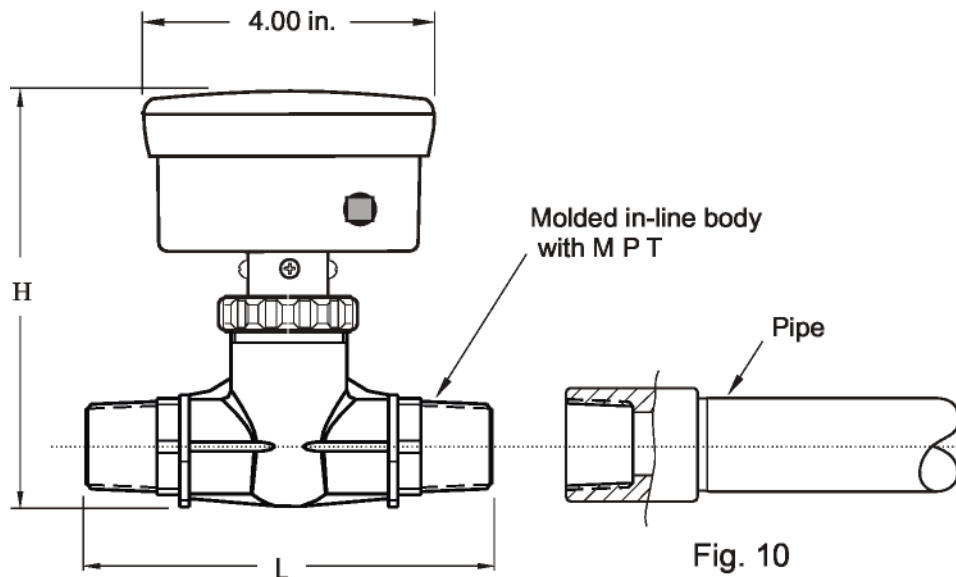

Fig. 10

Nominal Pipe Size	Body Description	Length	Height
3/8"	3/8" MPT-low flow	4.73"	5.70"
3/8"	3/8" MPT-std flow	4.73"	5.79"
1/2"	1/2" MPT-low flow	5.09"	5.70"
1/2"	1/2" MPT-std flow	5.09"	5.79"
3/4"	3/4" MPT-low flow	5.25"	5.79"
3/4"	3/4" MPT-std flow	5.25"	5.97"
1.0"	1.0" MPT-low flow	5.65"	5.97"
1.0"	1.0" MPT-std flow	5.65"	5.97"
1.5"	1.5" MPT-all flow ranges	7.00"	6.50"
2.0"	2.0" MPT-all flow ranges	7.00"	6.75"

8.0 How To Install Your F-2000 Molded PVC Fitting (TE)

Note: Tee fittings are I.P.S. Pipe, Slip glue joints.

Step 1 Select an area on the pipe as outlined in section 4.1.

Step 2 Remove the F-2000 sensor from the tee fitting. **Do not glue the Tee while the sensor is installed.**

Step 3 Install the F-2000 tee fitting as you would any other plastic pipe solvent weld (glue) fitting. Do not use too much glue. Excessive glue may create a disturbance in the flow stream which will effect the accuracy of the meter.

Step 4 The F-2000 can be mounted on horizontal or vertical runs of pipe. Mounting at the vertical (twelve o'clock) position on horizontal pipe is recommended (see figure 5). Mounting anywhere around the diameter of vertical pipe is acceptable, however, the pipe must be completely full of water at all times. See figure 3, 4 and 5.

Step 5 Install the F-2000 sensor. Be sure two O-rings are located on the sensor body. The O-rings have been lubricated at the factory with silicone oil. Push the sensor assembly into the saddle with a twisting motion. The notch on the sensor body must fit into the slot on the saddle. Be sure the sensor is fully inserted into the saddle. **HAND TIGHTEN** the black union nut.

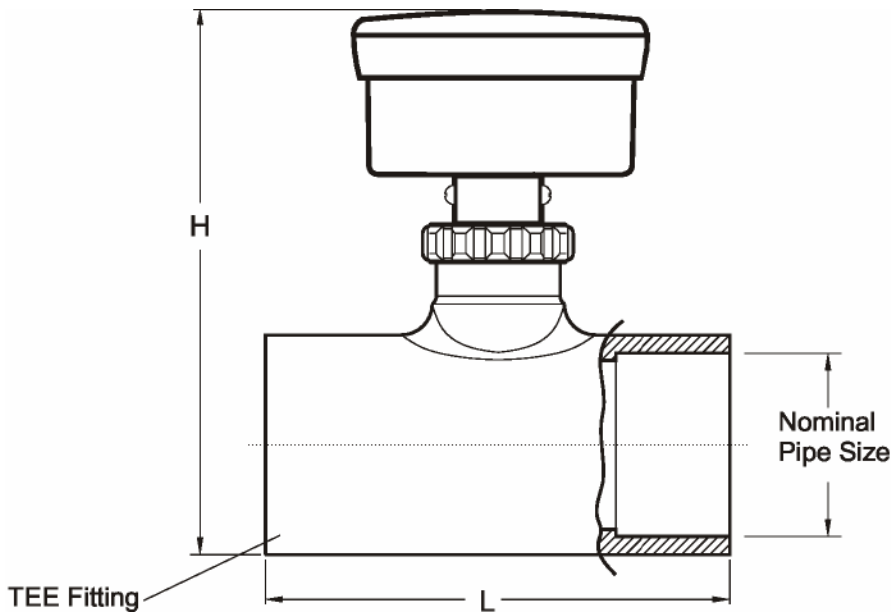
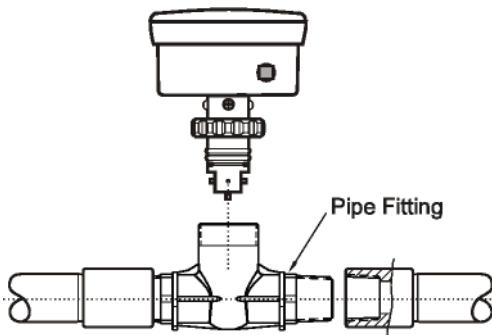

Fig. 11

Nominal Pipe Size	Height (H)	Length (L)	Replacement Tee
1" I PS	6"	4"	76000-978
1-1/2" I PS	6-5/8"	4-1/2"	76000-975
2" I PS	7-1/8"	4-3/4"	76000-976

IPS: International Pipe Standard

Molded In-Line Body Parts List



Complete Kit Ordering Numbers

Molded In-Line Pipe Fittings - U.S. (IPS) M/NPT	
Kit No	Description
38M1	3/8" MPT .800 - 8.000 GPM - PP
38M2	3/8" MPT .400 - 4.000 GPM - PP
38F1	3/8" MPT .800 - 8.000 GPM - PVDF
38F2	3/8" MPT .400 - 4.000 GPM - PVDF
50M1	1/2" MPT 2.00-20.00 GPM-PP
50M2	1/2" MPT .500 - 5.000 GPM - PP
50F1	1/2" MPT 2.00-20.00 GPM-PVDF
50F2	1/2" MPT .500 - 5.000 GPM - PVDF
75M1	3/4" MPT 3.00-30.00 GPM-PP
75M2	3/4" MPT .800 - 8.000 GPM - PP
75F1	3/4" MPT 3.00-30.00 GPM-PVDF
75F2	3/4" MPT .800 - 8.000 GPM - PVDF
10M1	1" MPT 5.00-50.00 GPM-PP
10M2	1" MPT 2.00 - 20.00 GPM - PP
10F1	1" MPT 5.00-50.00 GPM-PVDF
10F2	1" MPT 2.00 - 20.00 GPM - PVDF
15M1	1-1/2" MPT 4.00 - 40.00 GPM - PP
15M2	1-1/2" MPT 6.00 - 60.00 GPM - PP
15M3	1-1/2" MPT 10.0-100.0 GPM-PP
15F1	1-1/2" MPT 4.00 - 40.00 GPM - PVDF
15F2	1-1/2" MPT 6.00 - 60.00 GPM - PVDF
15F3	1-1/2" MPT 10.0 - 100.0 GPM - PVDF
20M1	2" MPT 4.00 - 40.00 GPM - PP
20M2	2" MPT 6.00 - 60.00 GPM - PP
20M3	2" MPT 10.0 - 100.0 GPM - PP
20M4	2" MPT 20.0 - 200.0 GPM - PP
20F1	2" MPT 4.00-40.00 GPM-PVDF
20F2	2" MPT 6.00 - 60.00 GPM - PVDF
20F3	2" MPT 10.0 - 100.0 GPM - PVDF
20F4	2" MPT 20.0 - 200.0 GPM - PVDF

Complete kits include:

- 1) Molded inline body fitting
- 1) Instruction manual

Saddle Parts List

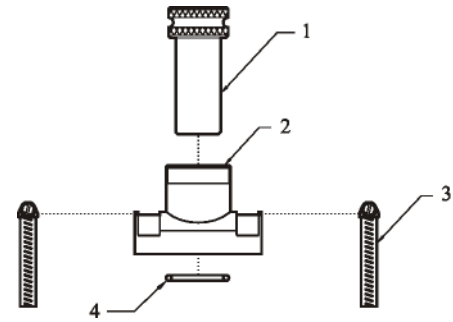

Replacement Part Numbers

Item	Part No .	Description
1	76000-830	Alignmenttool
2	91001-115	Saddle, 1-1/2" pipe (50mm)
	91 0 01-11	Saddle, 2" pipe (63mm)
	91001-116	Saddle, 3" pipe (90mm)
	76100-087	Saddle, 4" pipe (110mm)
	76100-088	Saddle, 6" pipe (160mm)
	76100-089	Saddle, 8" pipe (200mm)
	76100-139	Saddle, 10" & 12" pipe
3	90008-010	Hose-Clamp #28 for 1-1/2" pipe
	90008-137	Hose-Clamp #40 for 2" pipe
	90008-015	Hose-Clamp #52 for 3" pipe
	90008-018	Hose-Clamp #72 for 4" pipe
	90008-019	Hose-Clamp #116 for 6" pipe
	90008-020	Hose-Clamp #152 for 8" pipe
	90008-348	Hose-Clamp #188 for 10" pipe
	90008-349	Hose-Clamp #224 for 12" pipe
4	90003-108	O-ring / Vitonfor 1-1/2", 2", 3"
	90003-114	O-ring / Vitonfor 4", 6", 8", 10", 12"

Complete Kit Ordering Numbers

Metric (DIN 8062) Pipe Saddle	
Kit No	Description
05K0	50mm Metric pipe, Pn10, PVDF
05K6	50mm Metric pipe, Pn16, PVDF
06K0	63mm Metric pipe, Pn10, PVDF
06K6	63mm Metric pipe, Pn16, PVDF
09K0	90mm Metric pipe, Pn10, PVDF
09K6	90mm Metric pipe, Pn16, PVDF
11A0	110mm Metric pipe, Pn10, PVC
11A6	110mm Metric pipe, Pn16, PVC
16A0	160mm Metric pipe, Pn10, PVC
16A6	160mm Metric pipe, Pn16, PVC
20A0	200mm Metric pipe, Pn10, PVC

U.S. (IPS) Pipe Saddle Fittings	
Kit No	Description
15K4	1-1/2" IPS pipe, schedule 40, PVDF
15K8	1-1/2" IPS pipe, schedule 80, PVDF
20K4	2" IPS pipe, schedule 40, PVDF
20K8	2" IPS pipe, schedule 80, PVDF
30K4	3" IPS pipe, schedule 40, PVDF
30K8	3" IPS pipe, schedule 80, PVDF
40A4	4" IPS pipe, schedule 40, PVC
40A8	4" IPS pipe, schedule 80, PVC
60A4	6" IPS pipe, schedule 40, PVC
60A8	6" IPS pipe, schedule 80, PVC
80A4	8" IPS pipe, schedule 40, PVC
80A8	8" IPS pipe, schedule 80, PVC
100A4	10" IPS pipe, schedule 40, PVC
100A8	10" IPS pipe, schedule 80, PVC
120A4	12" IPS pipe, schedule 40, PVC
120A8	12" IPS pipe, schedule 80, PVC

Complete kits include:

- 1) Saddle fitting
- 2) Pipe clamps
- 1) O-ring seal
- 1) Installation alignment tool
- 1) Instruction manual

Machined In-Line Block Parts

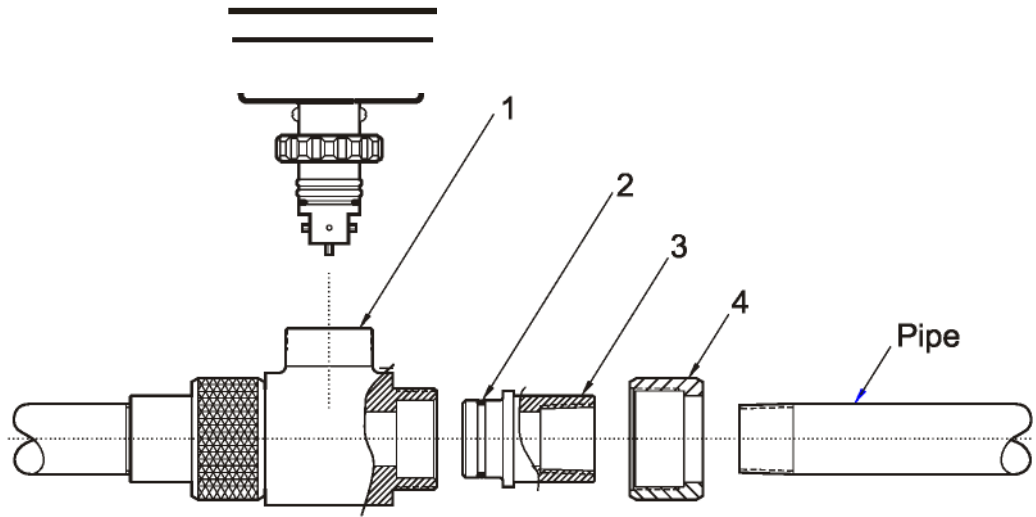

Replacement Part Numbers

Item	Part No .	Description
1	76100-107	Body .38" .8-8 GPM PP
	76100-109	Body .38" .4-4 GPM PP
	76100-106	Body .50" 2-20 GPM PP
	76100-108	Body .50" .5-5 GPM PP
	76100-105	Body .75" 4-40 GPM PP
	76100-107	Body .75" .8-8 GPM PP
	76100-104	Body 1.0" 6-60 GPM PP
	76100-106	Body 1.0" 2-20 GPM PP
	76100-134	Body 1.5" 15-150 GPM PP
	76100-135	Body 1.5" 10-100 GPM PP
	76100-136	Body 1.5" 6-60 GPM PP
	76100-137	Body 1.5" 2-20 GPM PP
	76100-138	Body 1.5" 1-10 GPM PP
	76100-128	Body 2.0" 30-300 GPM PP
	76100-129	Body 2.0" 15-150 GPM PP
	76100-130	Body 2.0" 10-100 GPM PP
	76100-131	Body 2.0" 6-60 GPM PP
	76100-132	Body 2.0" 4-40 GPM PP
76100-133	Body 2.0" 2-20 GPM PP	
2	90003-079	O-ring for .38" - 1.0" Viton
	90003-134	O-ring for 1.5" Viton
	90003-118	O-ring for 2.0" Viton
3	76001-052	Adapter .38" .8-8 GPM PP
	76001-053	Adapter .38" .4-4 GPM PP
	76001-050	Adapter .50" 2-20 GPM PP
	76001-051	Adapter .50" .5-5 GPM PP
	76001-048	Adapter .75" 4-40 GPM PP
	76001-049	Adapter .75" .8-8 GPM PP
	76001-046	Adapter 1.0" 6-60 GPM PP
	76001-047	Adapter 1.0" 2-20 GPM PP
76001-193	Adapter 1.5" PP	
76001-195	Adapter 2.0" PP	
4	76001-066	Union nut .38"-1.0" alum.
	76001-196	Union nut 1.5" alum.
	76001-197	Union nut 2.0" alum.

Complete Kit Ordering Numbers

Machined In-Line Pipe Fittings - U.S. (IPS)	
Kit No	Description
38P1	3/8" In-Line block, .8-8 GPM, PP
38P2	3/8" In-Line block, .4-4 GPM, PP
38K1	3/8" In-Line block, .8-8 GPM, PVDF
38K2	3/8" In-Line block, .4-4 GPM, PVDF
50P1	1/2" In-Line block, 2-20 GPM, PP
50P2	1/2" In-Line block, .5-5 GPM, PP
50K1	1/2" In-Line block, 2-20 GPM, PVDF
50K2	1/2" In-Line block, .5-5 GPM, PVDF
75P1	3/4" In-Line block, 4-40 GPM, PP
75P2	3/4" In-Line block, .8-8 GPM, PP
75K1	3/4" In-Line block, 4-40 GPM, PVDF
75K2	3/4" In-Line block, .8-8 GPM, PVDF
10P1	1" In-Line block, 6-60 GPM, PP
10P2	1" In-Line block, 2-20 GPM, PP
10K1	1" In-Line block, 6-60 GPM, PVDF
10K2	1" In-Line block, 2-20 GPM, PVDF
15P1	1.5" In-Line block, 15-150 GPM, PP
15P2	1.5" In-Line block, 10-100 GPM, PP
15P3	1.5" In-Line block, 6-60 GPM, PP
15P4	1.5" In-Line block, 2-20 GPM, PP
15P5	1.5" In-Line block, 1-10 GPM, PP
20P1	2.0" In-Line block, 30-300 GPM, PP
20P2	2.0" In-Line block, 15-150 GPM, PP
20P3	2.0" In-Line block, 10-100 GPM, PP
20P4	2.0" In-Line block, 6-60 GPM, PP
20P5	2.0" In-Line block, 4-40 GPM, PP
20P6	2.0" In-Line block, 2-20 GPM, PP

Complete kits include:

- 1) Body fitting
- 2) Pipe adapters
- 2) Adapter O-ring seals
- 2) Union nuts
- 1) Instruction manual